

性能曲线/Performance curve

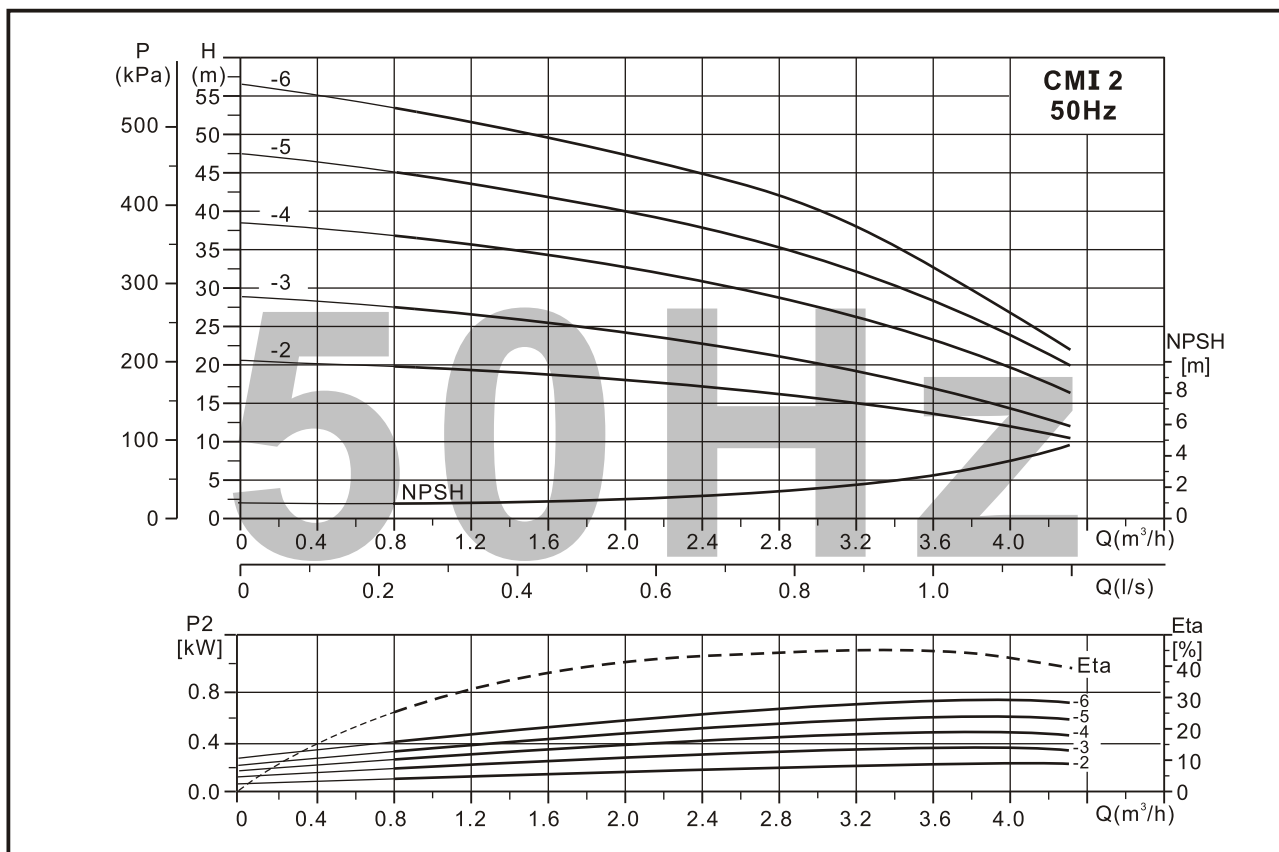

性能表/Performance table

泵型号 Model	配用电机 Driving motor P ₂ (kW)	流量 Q (m³/h)	0.8	1.2	1.6	2.0	2.4	2.8	3.2	3.6	4.0
CMI2-2	0.25	扬程 H (m)	19.5	19	18.5	18	17	16.5	14.5	13.5	12
CMI2-3	0.37		27	26	25	24	23	22	20	17	15
CMI2-4	0.55		36	35	34	32	31	29	27	23	20
CMI2-5	0.55		44	43	42	40	38	36	33	28.5	24
CMI2-6	0.75		53	51.5	49	47	44	41	37	32	27

安装图/Installation sketch

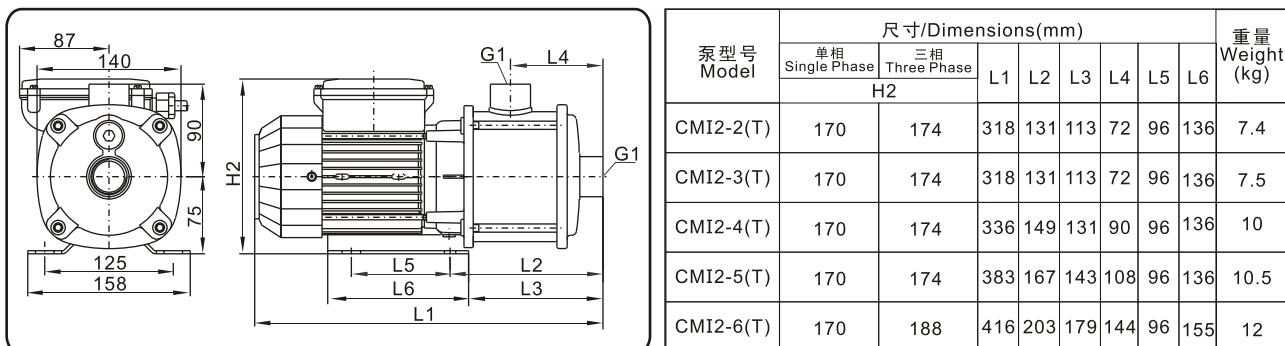

性能曲线/Performance curve

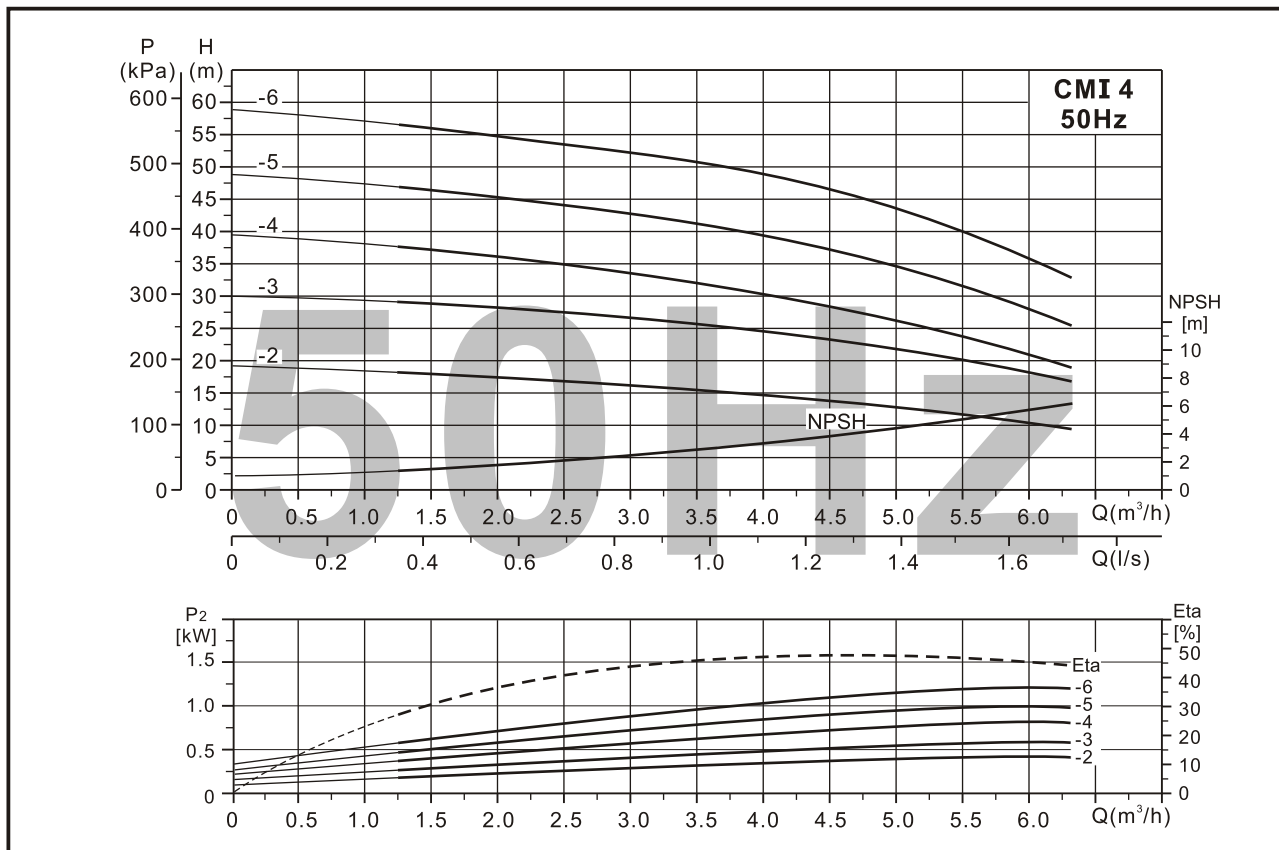

性能表/Performance table

泵型号 Model	配用电机 Driving motor P ₂ (kW)	流量 Q (m ³ /h)	1.0	1.5	2.0	2.5	3.0	3.5	4.0	4.5	5.0	5.5	6.0
CMI4-2	0.37	扬程 H (m)	18.5	18	17.5	17	16	15.5	15	13.5	13	11	10
CMI4-3	0.55		29	28.5	28	27	26.5	25.5	25	23	22	20	18
CMI4-4	0.75		38	37	36	34	33.5	32	30	28	27	24	20
CMI4-5	1.0		47	46	45	44	42.5	41	40	36	35	32	27
CMI4-6	1.3		56.5	55	54	53	52.5	51	49	45	44	42	36

安装图/Installation sketch

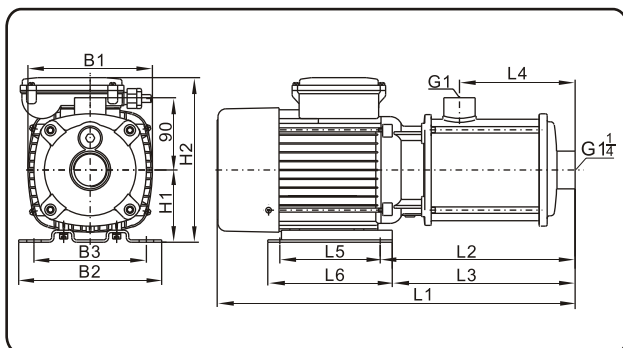

泵型号 Model	尺寸/Dimensions(mm)												重量 Weight (kg)	
	B1	B2	B3	H1	单相 Single Phase		三相 Three Phase		L2	L3	L4	L5		L6
					H2	L1	H2	L1						
CMI4-2(T)	140	158	125	75	170	318	174	318	131	113	72	96	136	8.0
CMI4-3(T)	140	158	125	75	170	347	174	318	131	113	72	96	136	10
CMI4-4(T)	140	158	125	75	182	362	188	362	149	125	90	96	155	11.5
CMI4-5(T)	140	158	125	75	182	380	188	380	167	143	108	96	155	12.5
CMI4-6(T)	155	178	140	90	209	446	211	446	243	228	144	125	155	15

性能曲线/Performance curve

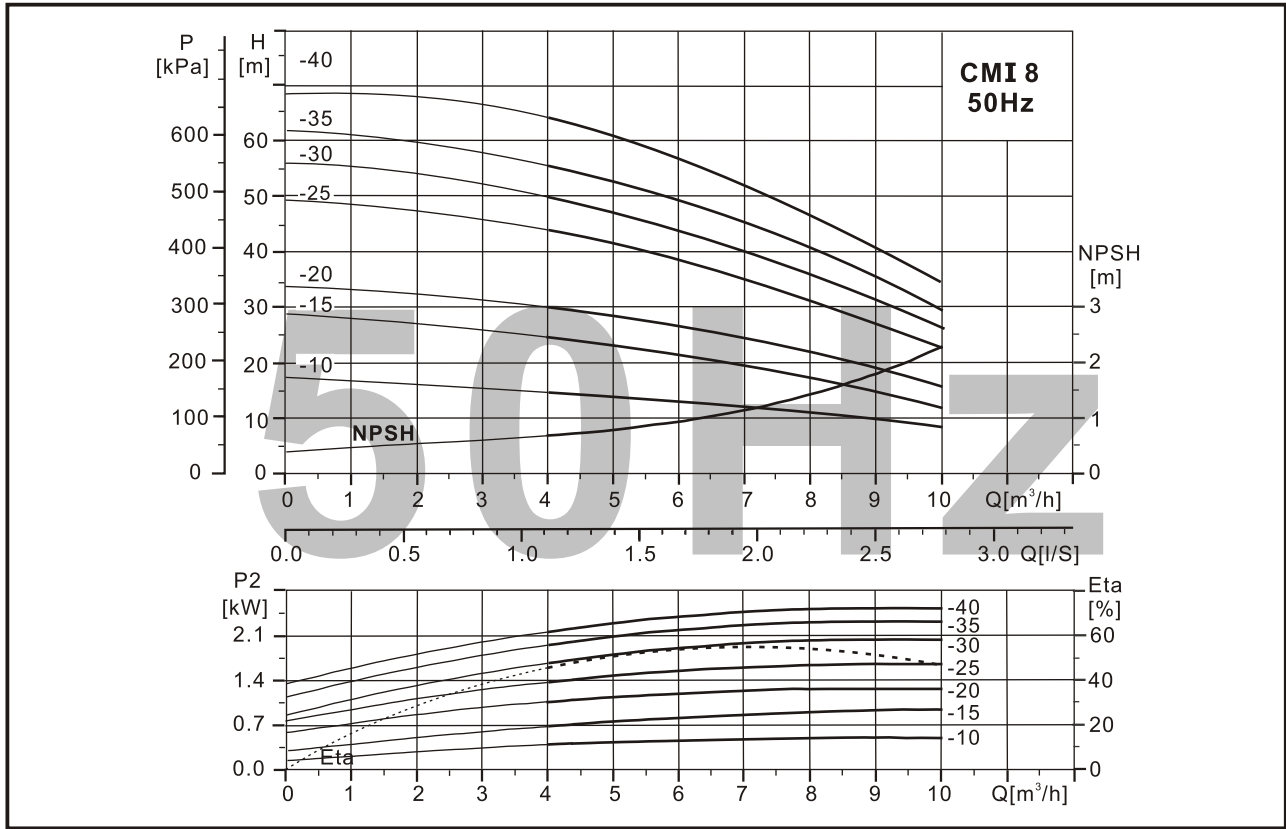

性能表/Performance table

泵型号 Model	配用电机 Driving motor P ₂ (kW)	流量 Q (m ³ /h)	4.0	5.0	6.0	7.0	8.0	9.0	10
CMI8-10	0.55	扬程 H (m)	15	14	13	12.5	12	9	8
CMI8-15	0.75		25	23	22	21	20	14	12
CMI8-20	1.0		32	29	27	25	24	21	17
CMI8-25	1.5		43	40	38	34	27	25	20
CMI8-30	1.85		50	46	44	40	36	30	26
CMI8-35	2.2		56	51	48	44	43	35	28
CMI8-40	2.2		65	57.5	57	50	48	42	34

安装图/Installation sketch

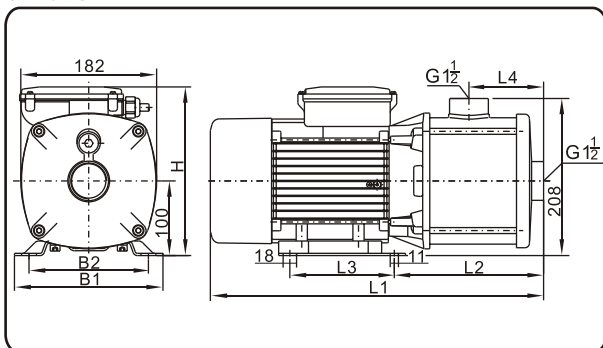

泵型号 Model	尺寸/Dimensions(mm)										重量 Weight (kg)		
	单相 Single Phase					三相 Three Phase						L2	L4
	B1	B2	L1	L3	H	B1	B2	L1	L3	H			
CMI8-10(T)	158	125	377	96	206	158	125	377	96	212	185	100	10
CMI8-15(T)	158	125	377	96	206	158	125	377	96	212	185	100	11
CMI8-20(T)	158	125	377	96	206	158	125	377	96	212	185	100	13
CMI8-25(T)	158	125	408	96	232	158	125	408	96	217	200	100	16
CMI8-30(T)	199	160	449	140	244	158	125	408	96	217	200	100	21
CMI8-35(T)	199	160	479	140	244	158	125	438	96	217	230	130	22
CMI8-40(T)	199	160	479	140	244	158	125	438	96	217	230	130	23

注:可按客户要求提供G2接口泵头/pump cover with G2 inlet/outlet is available

性能曲线/Performance curve

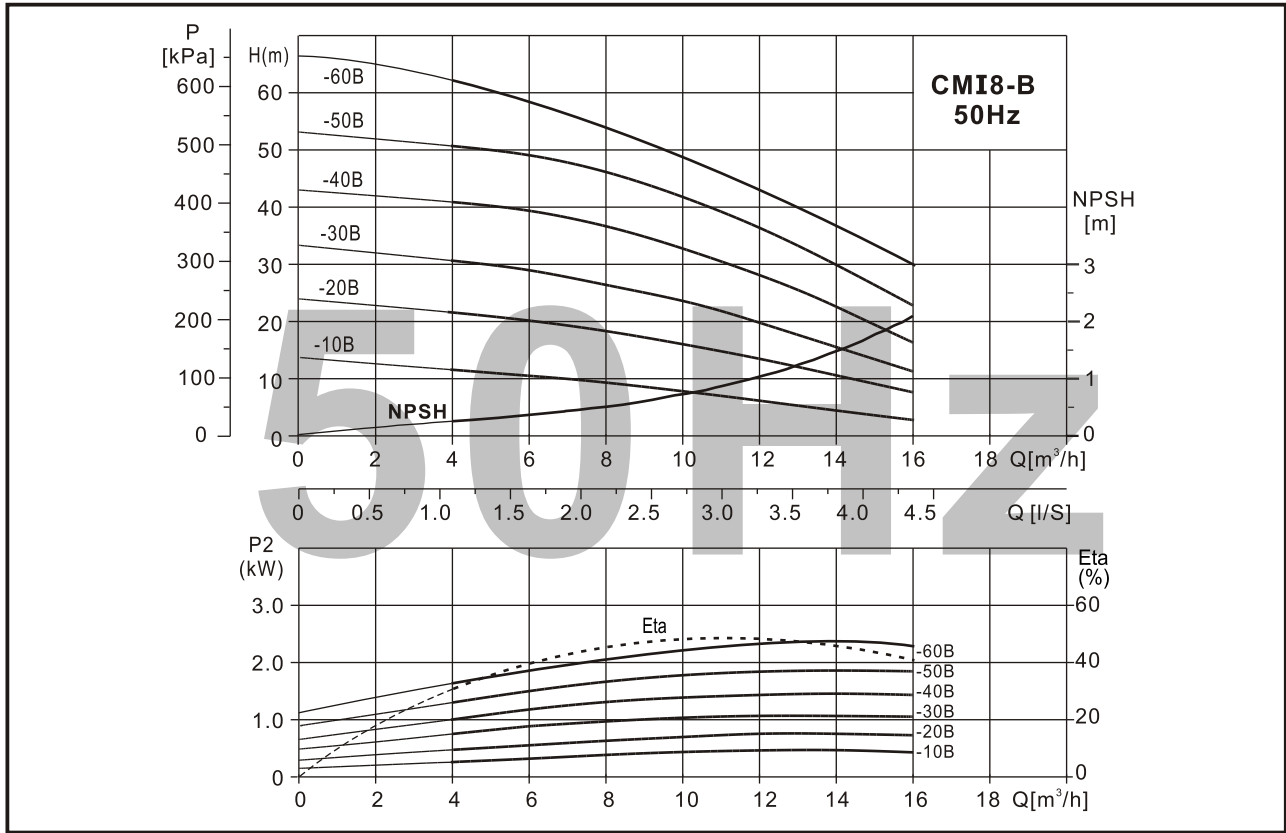

性能表/Performance table

泵型号 Model	配用电机 Driving motor P ₂ (kW)	流量 Q (m³/h)	4.0	6.0	8.0	10	12	14	16
CMI8-10B	0.55	扬程 H (m)	11	10	9	8	7	6	5
CMI8-20B	0.75		22	20	19	18	13	11	8
CMI8-30B	1.1		31	29	26	24	20	16	11
CMI8-40B	1.5		41	39	37	33	28	23	17
CMI8-50B	2.2		51	49	46.5	42	37	30	23
CMI8-60B	3.0		62	58	52	48	42	36	30

安装图/Installation sketch

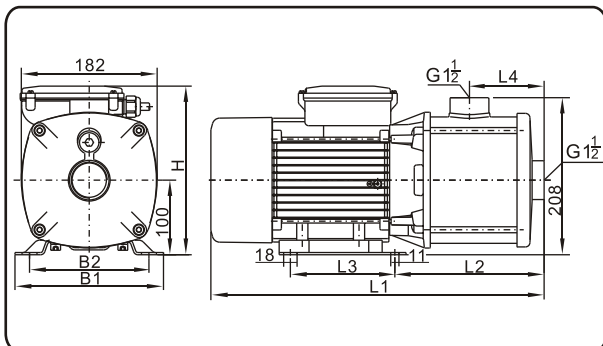

泵型号 Model	尺寸/Dimensions(mm)												重量 Weight (kg)	
	单相 Single Phase						三相 Three Phase							
	B1	B2	L1	L2	L3	H	B1	B2	L1	L2	L3	H		
CMI8-10B(T)	158	125	377	185	96	206	158	125	377	185	96	212	100	10
CMI8-20B(T)	158	125	377	185	96	206	158	125	377	185	96	212	100	11
CMI8-30B(T)	158	125	408	200	96	232	158	125	408	200	96	217	100	12
CMI8-40B(T)	158	125	438	230	96	232	158	125	438	230	96	217	130	15
CMI8-50B(T)	199	160	539	290	140	244	158	125	498	290	96	217	190	24
CMI8-60BT	—	—	—	—	—	—	199	160	559	290	140	212	190	26

注:可按客户要求提供G2接口泵头/ Pump cover with G2 inlet/outlet is available

性能曲线/Performance curve

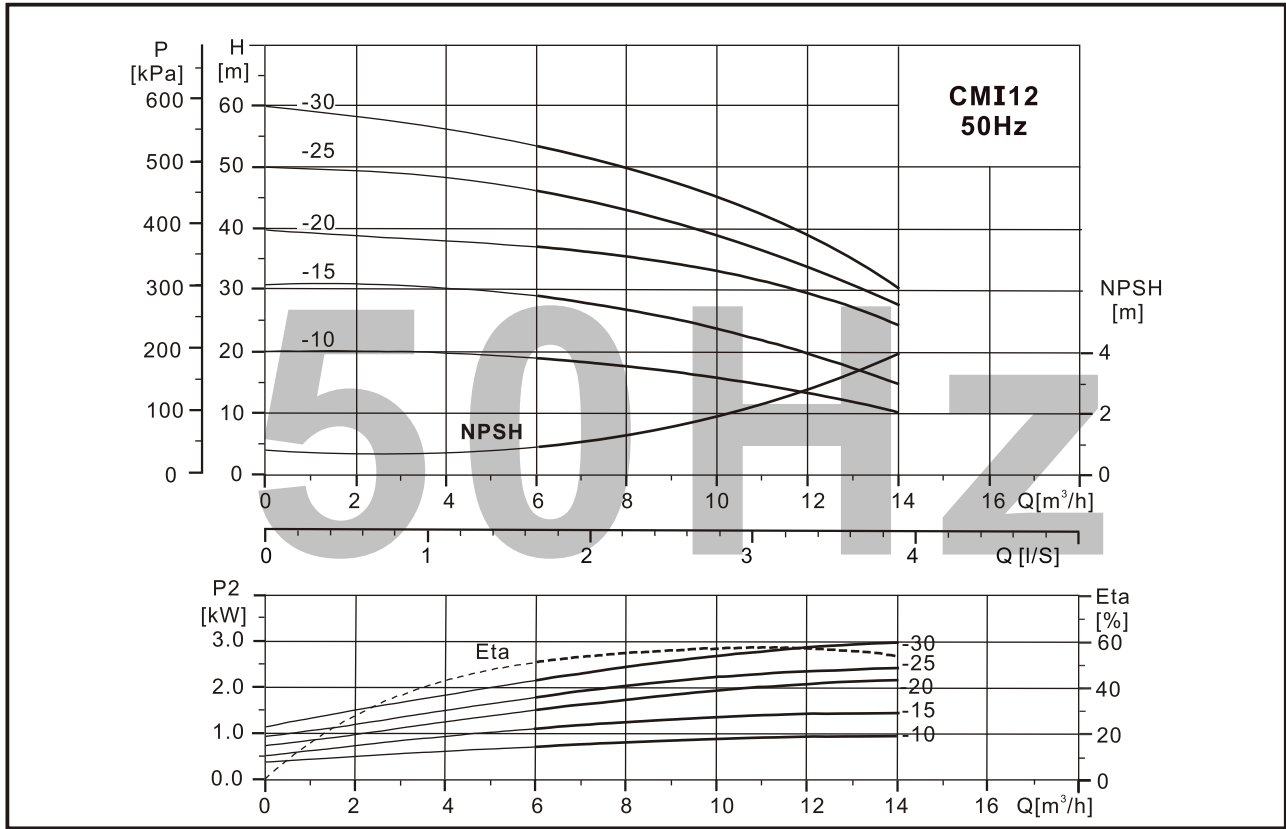

性能表/Performance table

泵型号 Model	配用电机 Driving motor P ₂ (kW)	流量 Q (m³/h)	6.0	7.0	8.0	9.0	10	11	12	13	14
CMI12-10	1.0	扬程 H (m)	19	18	17.5	16	15.5	14	13.5	12	10.5
CMI12-15	1.5		28	27	26	25	24	22	20	18	15
CMI12-20	1.85		38	36	35	32	31	29	28	24	20
CMI12-25	2.2		47	45	43	41.5	39	36	33.5	30.5	27
CMI12-30	3.0		53.5	52	50	47.5	45	42	39	35	30

安装图/Installation sketch

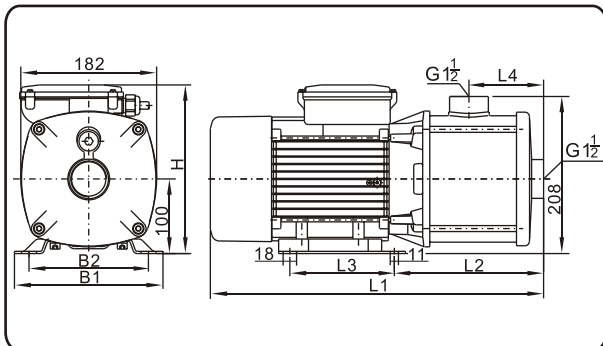

泵型号 Model	尺寸/Dimensions(mm)										重量 Weight (kg)		
	单相 Single Phase					三相 Three Phase							
	B1	B2	L1	L3	H	B1	B2	L1	L3	H			
CMI12-10(T)	158	125	377	96	206	158	125	377	96	212	185	100	11
CMI12-15(T)	158	125	408	96	214	158	125	408	96	217	200	100	13
CMI12-20(T)	199	160	449	140	244	158	125	408	96	217	200	100	20
CMI12-25(T)	199	160	449	140	244	158	125	409	96	217	200	100	23
CMI12-30T	—	—	—	—	—	199	160	469	140	212	200	100	26

注:可按客户要求提供G2接口泵头/pump cover with G2 inlet/outlet is available

性能曲线/Performance curve

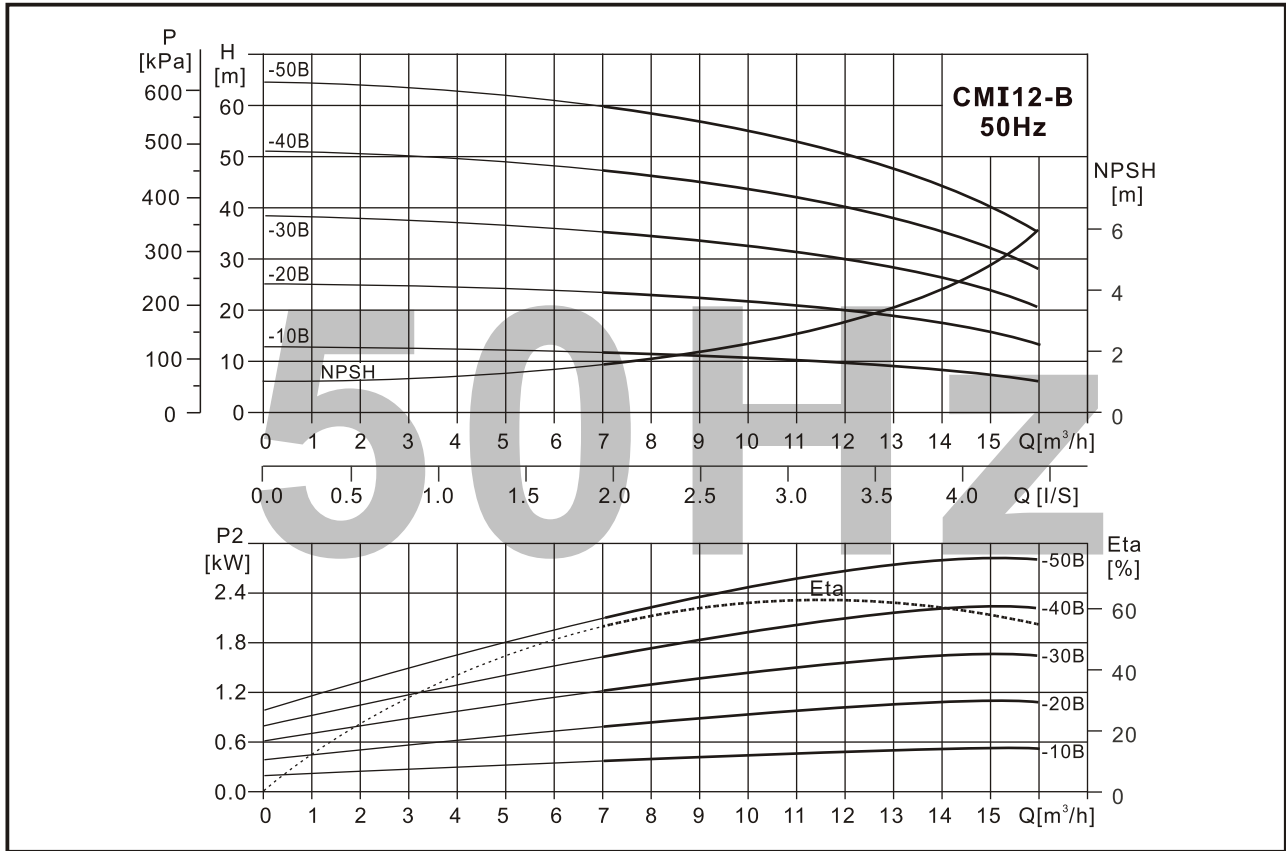

性能表/Performance table

泵型号 Model	配用电机 Driving motor P ₂ (kW)	流量 Q (m ³ /h)	7.0	8.0	9.0	10	11	12	13	14	15	16
CMI12-10B	0.75	扬程 H (m)	12	11.5	11	10.5	10	9.5	9	8	7	6
CMI12-20B	1.1		23	22.5	22	21	20.5	19.5	18.5	17	15.5	13
CMI12-30B	1.85		35	34.5	33.5	32.5	31	29.5	28	26	23.5	20
CMI12-40B	2.2		47	46	45	43.5	41.5	39.5	37.5	35	31.5	27.5
CMI12-50B	3.0		60	58	56.5	55	52.5	50	47	44	40	35

安装图/Installation sketch

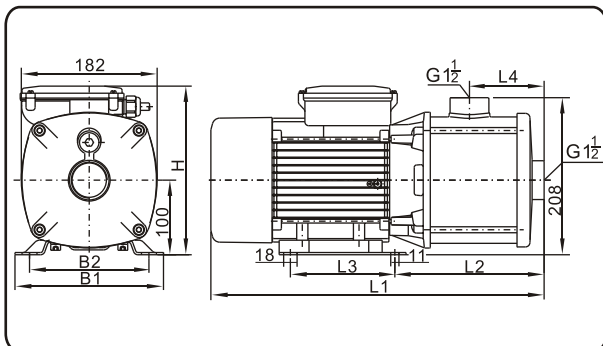

泵型号 Model	尺寸/Dimensions(mm)												重量 Weight (kg)	
	单相 Single Phase						三相 Three Phase							
	B1	B2	L1	L2	L3	H	B1	B2	L1	L2	L3	H		
CMI12-10B(T)	158	125	377	185	96	206	158	125	377	185	96	212	100	11
CMI12-20B(T)	158	125	408	200	96	214	158	125	408	200	96	217	100	12
CMI12-30B(T)	199	160	449	200	140	244	158	125	408	200	96	217	100	22
CMI12-40B(T)	199	160	479	200	140	244	158	125	438	200	96	217	130	23
CMI12-50B	—	—	—	—	—	—	199	160	539	290	140	212	190	26

注:可按客户要求提供G2接口泵头/ Pump cover with G2 inlet/outlet is available

性能曲线/Performance curve

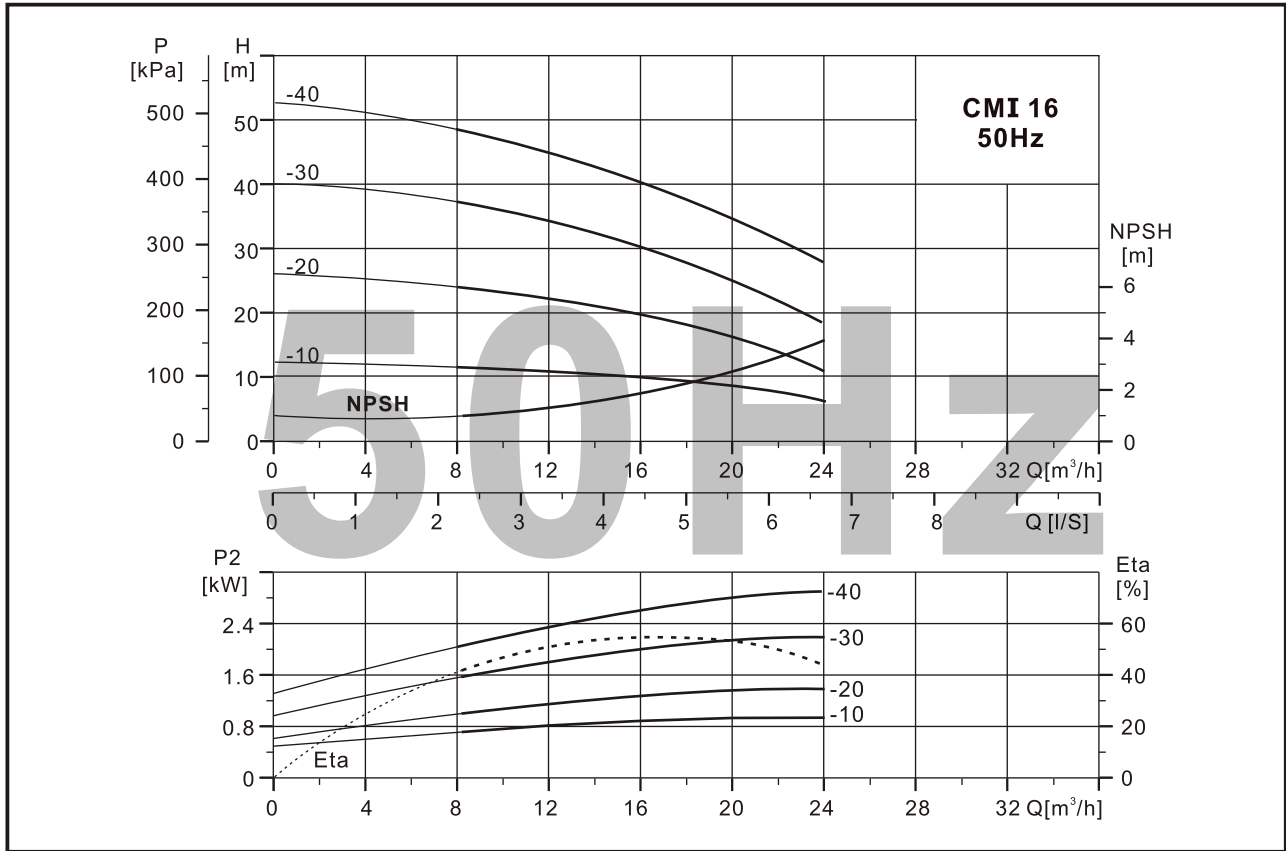

性能表/Performance table

泵型号 Model	配用电机 Driving motor P ₂ (kW)	流量 Q (m³/h)	8	10	12	14	16	18	20	22	24
CMI16-10	1.0	扬程 H (m)	12	11.5	11	10.5	10	9	8	7	6
CMI16-20	1.5		24	23	22	21	20	19	16	14	12
CMI16-30	2.2		38	36	34	33	30	28	26	23	20
CMI16-40	3.0		50	48	46	44	40	38	36	32	28

安装图/Installation sketch

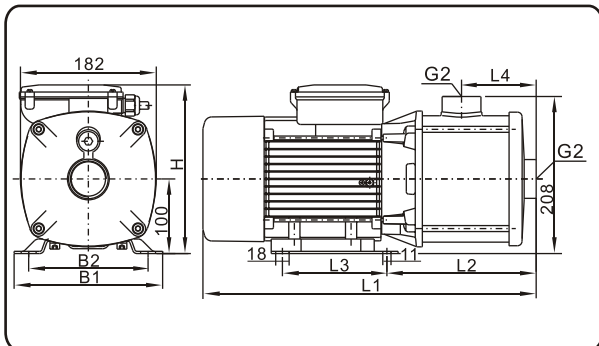

泵型号 Model	尺寸/Dimensions(mm)										重量 Weight (kg)		
	单相 Single Phase					三相 Three Phase						L2	L4
	B1	B2	L1	L3	H	B1	B2	L1	L3	H			
CMI16-10(T)	158	125	408	96	209	158	125	408	96	212	215	130	13
CMI16-20(T)	158	125	439	96	232	158	125	439	96	217	230	130	16
CMI16-30(T)	199	160	480	140	244	199	160	580	140	212	230	130	22
CMI16-40T	—	—	—	—	—	199	160	545	140	212	275	175	27

性能曲线/Performance curve

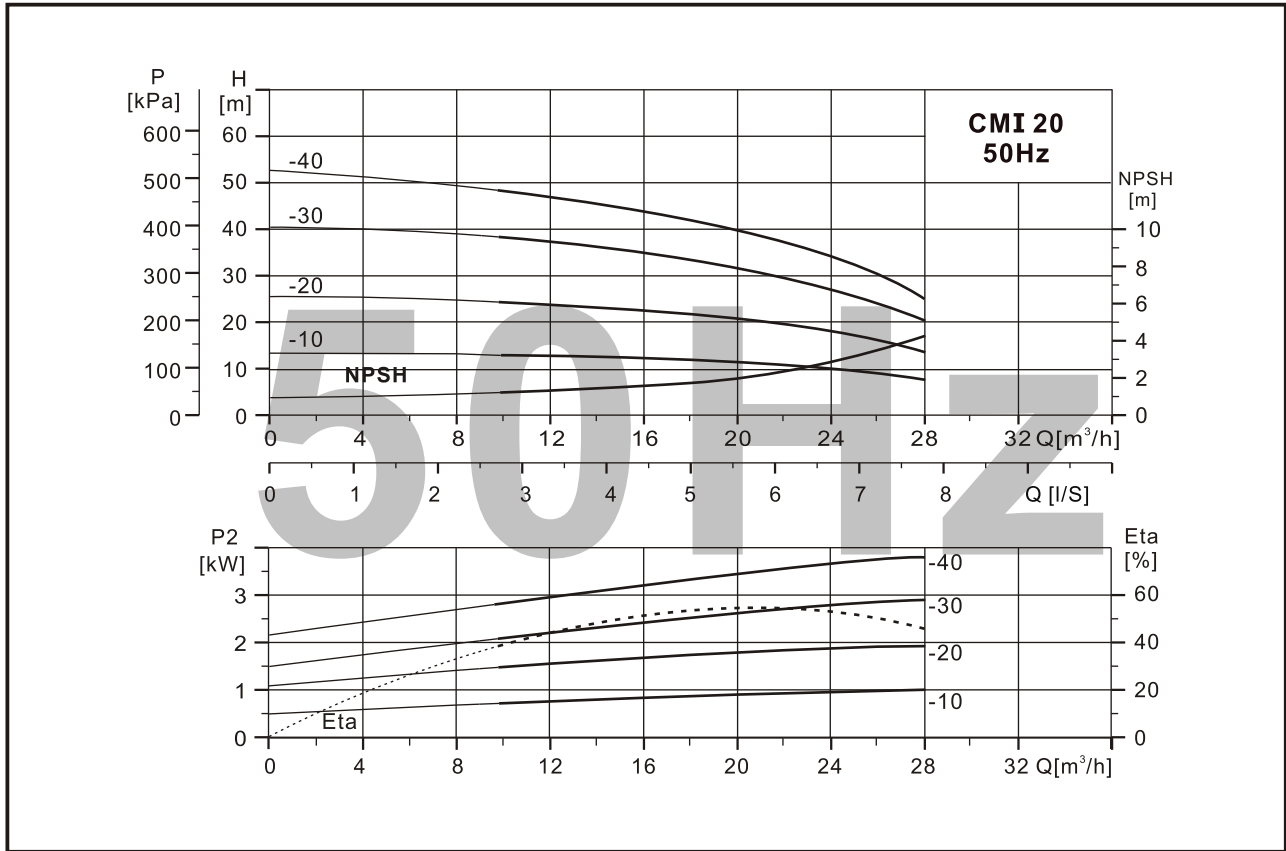

性能表/Performance table

泵型号 Model	配用电机 Driving motor P ₂ (kW)	流量 Q (m ³ /h)	扬程 H (m)									
			10	12	14	16	18	20	22	24	26	28
CMI20-10	1.0	扬程 H (m)	13	12.5	12	11.5	11	10.5	10	9	8.5	7.5
CMI20-20	1.85		25	24	23	22	21	20	18	16	14	12
CMI20-30	3.0		39	38	36	35	33	31.5	30	27	24	21

安装图/Installation sketch

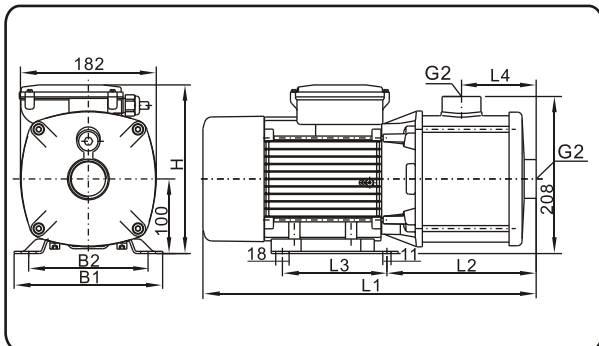

泵型号 Model	尺寸/Dimensions(mm)										重量 Weight (kg)		
	单相 Single Phase					三相 Three Phase						L2	L4
	B1	B2	L1	L3	H	B1	B2	L1	L3	H			
CMI20-10(T)	158	125	408	96	209	158	125	408	96	212	215	130	19
CMI20-20(T)	199	160	480	140	244	158	125	439	96	217	230	130	21
CMI20-30T	—	—	—	—	—	199	160	500	140	212	230	130	24

性能曲线/Performance curve

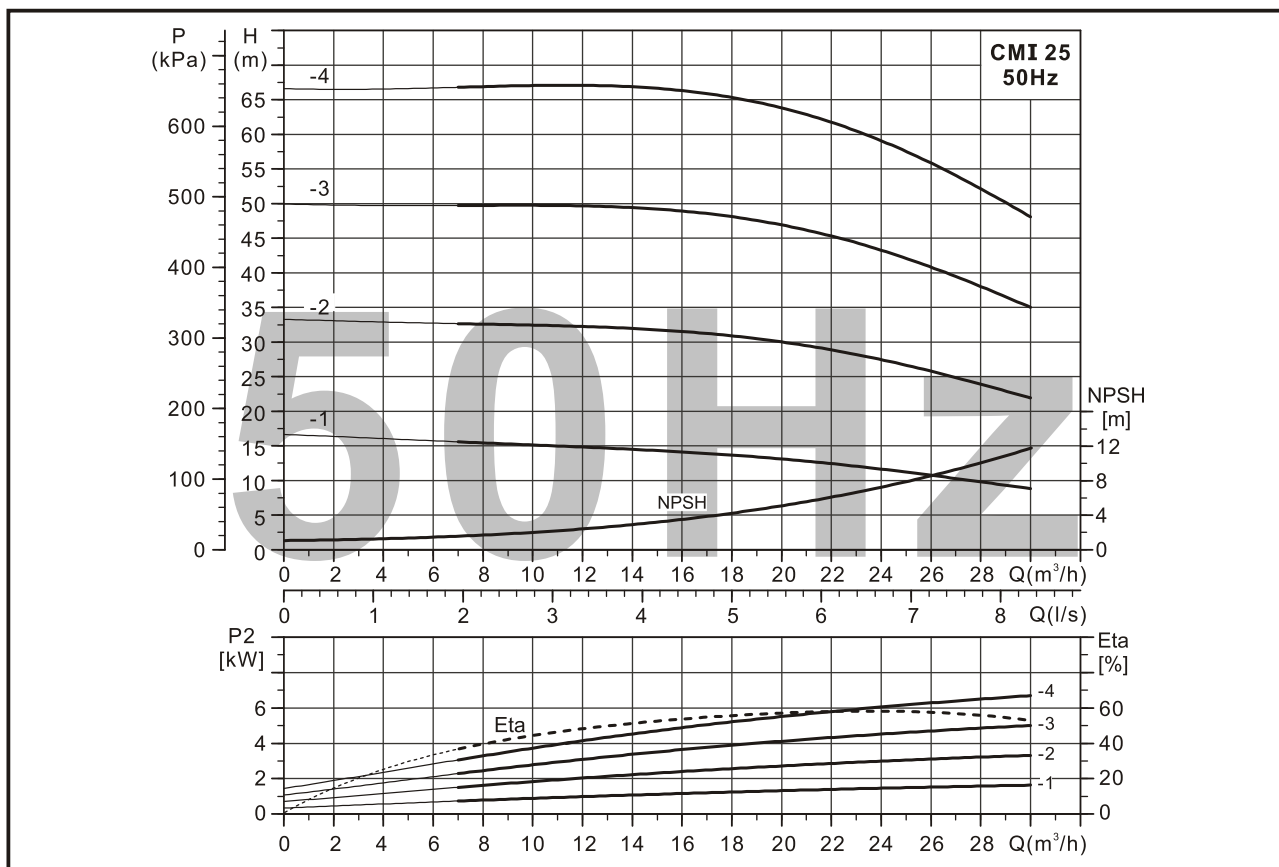

性能表/Performance table

泵型号 Model	配用电机 Driving motor P ₂ (kW)	流量 Q (m³/h)	8	10	12	14	16	18	20	22	24	26	28
CMI 25-1(T)	2.2	扬程 H (m)	15.5	15	15	14.5	14	13.5	13	12	11.5	11	10
CMI 25-2T	4.0		33	32.5	32	31.5	31	30.5	30	28	27	26	24
CMI 25-3T	5.5		50	50	50	49	48	47	46	45	43	41	38
CMI 25-4T	7.5		66	66	66	66	66	65	64	62	58	56	52

安装图/Installation sketch

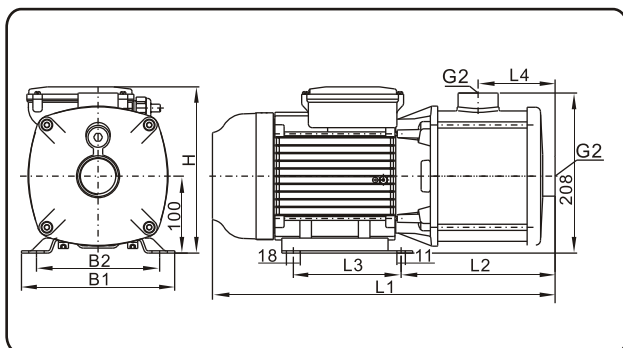

泵型号 Model	尺寸/Dimensions(mm)								重量 Weight (kg)
	B1	B2	L1	L2	L3	L4	单相 Single Phase H	三相 Three Phase H	
CMI 25-1(T)	199	160	448	200	140	100	244	217	21
CMI 25-2T	199	160	510	235	140	100	—	260	29
CMI 25-3T	228	190	560	235	140	100	—	295	35
CMI 25-4T	228	190	620	288	140	130	—	295	38